

PIPELINE CROSSING AGREEMENT

Mile Post: 766.36, Toledo Branch Subdivision
Location: Toledo, Lincoln County, Oregon

THIS AGREEMENT ("Agreement") is made and entered into as of May 28, 2021, ("Effective Date") by and between **UNION PACIFIC RAILROAD COMPANY**, a Delaware corporation, ("Licensor") and **PORT OF TOLEDO**, to be addressed at 496 NW Hwy 20, Unit 1 Toledo, Oregon 97391 ("Licensee").

IT IS MUTUALLY AGREED BY AND BETWEEN THE PARTIES HERETO AS FOLLOWS:

Article 1. LICENSOR GRANTS RIGHT.

A. In consideration of the license fee to be paid by Licensee set forth below and in further consideration of the covenants and agreements to be performed by Licensee, Licensor hereby grants to Licensee the right to construct and thereafter, during the term hereof, maintain and operate one (1) underground three inch (3") plastic sanitary sewage pipeline encased in a ten inch (10") steel casing pipeline crossing only, including any appurtenances required for the operation of said pipeline (collectively, "Licensee's Facilities") across Licensor's real property, trackage, or other facilities located in Toledo, Lincoln County, State of Oregon ("Railroad Property"). The specific specifications and limited purpose for Licensee's Facilities on, along, across and under Railroad Property are described in and shown on the Print and Specifications dated May 03, 2021, attached hereto as **Exhibit A** and made a part hereof.

B. Licensee represents and warrants that Licensee's Facilities will (i) only be used for one (1) underground three inch (3") plastic sanitary sewage pipeline encased in a ten inch (10") steel casing pipeline crossing, and (ii) not be used to convey any other substance, any fiber optic cable, or for any other use, whether such use is currently technologically possible, or whether such use may come into existence during the life of this Agreement.

C. Licensee acknowledges that if it or its contractor provides Licensor with digital imagery depicting Licensee's Facilities ("Digital Imagery"), Licensee authorizes Licensor to use the Digital Imagery in preparing **Exhibit A**. Licensee represents and warrants that through a license or otherwise, it has the right to use the Digital Imagery and to permit Licensor to use the Digital Imagery in said manner.

Article 2. LICENSE FEE.

Upon execution of this Agreement, the Licensee shall pay to the Licensor a one-time License Fee of **Five Thousand Dollars (\$5,000.00)**.

Article 3. TERM.

This Agreement shall take effect as of the Effective Date first herein written and shall continue in full force and effect until terminated as provided in the "TERMINATION; REMOVAL OF LICENSEE'S FACILITIES" Section of **Exhibit B**.

Article 4. LICENSEE'S COMPLIANCE WITH GENERAL TERMS.

Licensee represents and warrants that all work on Licensee's Facilities performed by Licensee or its contractors will strictly comply with all terms and conditions set forth herein, including the General Terms and Conditions, attached hereto as Exhibit B and made a part hereof.

Article 5. INSURANCE.

A. During the term of this Agreement, Licensee shall fully comply or cause its contractor(s) to fully comply with the insurance requirements described in **Exhibit C**, attached hereto and made a part hereof. Upon request only, Licensee shall send copies of all insurance documentation (e.g., certificates, endorsements, etc.) to Licensor at the address listed in the "NOTICES" Section of this Agreement.

B. If Licensee is subject to statute(s) limiting its insurance liability and/or limiting its ability to obtain insurance in compliance with **Exhibit C** of this Agreement, those statutes shall apply.

Article 6. DEFINITION OF LICENSEE.

For purposes of this Agreement, all references in this Agreement to Licensee will include Licensee's contractors, subcontractors, officers, agents and employees, and others acting under its or their authority (collectively, a "Contractor"). If a Contractor is hired by Licensee to perform any work on Licensee's Facilities (including initial construction and subsequent relocation, maintenance, and/or repair work), then Licensee shall provide a copy of this Agreement to its Contractor(s) and require its Contractor(s) to comply with all terms and conditions of this Agreement, including the indemnification requirements set forth in the "INDEMNITY" Section of **Exhibit B**. Licensee shall require any Contractor to release, defend, and indemnify Licensor to the same extent and under the same terms and conditions as Licensee is required to release, defend, and indemnify Licensor herein.

Article 7. ATTORNEYS' FEES, EXPENSES, AND COSTS.

If litigation or other court action or similar adjudicatory proceeding is undertaken by Licensee or Licensor to enforce its rights under this Agreement, all fees, costs, and expenses, including, without limitation, reasonable attorneys' fees and court costs, of the prevailing Party in such action, suit, or proceeding shall be reimbursed or paid by the Party against whose interest the judgment or decision is rendered. The provisions of this Article shall survive the termination of this Agreement.

Article 8. WAIVER OF BREACH.

The waiver by Licensor of the breach of any condition, covenant or agreement herein contained to be kept, observed and performed by Licensee shall in no way impair the right of Licensor to avail itself of any remedy for any subsequent breach thereof.

Article 9. ASSIGNMENT.

A. Licensee shall not assign this Agreement, in whole or in part, or any rights herein granted, without the written consent of Licensor, which must be requested in writing by Licensee. Any assignment or attempted transfer of this Agreement or any of the rights herein granted, whether voluntary, by operation of law, or otherwise, without Licensor's written consent, will be absolutely void and may result in Licensor's termination of this Agreement pursuant to the "TERMINATION; REMOVAL OF LICENSEE'S FACILITIES" Section of **Exhibit B**.

B. Upon Licensor's written consent to any assignment, this Agreement will be binding upon and inure to the benefit of the parties thereto, successors, heirs, and assigns, executors, and administrators.

Article 10. SEVERABILITY.

Any provision of this Agreement which is determined by a court of competent jurisdiction to be invalid or unenforceable shall be invalid or unenforceable only to the extent of such determination, which shall not invalidate or otherwise render ineffective any other provision of this Agreement.

Article 11. NOTICES.

Except Licensee's commencement of work notice(s) required under **Exhibit B**, all other notices required by this Agreement must be in writing, and (i) personally served upon the business address listed below ("Notice Address"), (ii) sent overnight via express delivery by a nationally recognized overnight delivery service such as Federal Express Corporation or United Parcel Service to the Notice Address, or (iii) by certified mail, return receipt requested to the Notice Address. Overnight express delivery notices will be deemed to be given upon receipt. Certified mail notices will be deemed to be given three (3) days after deposit with the United States Postal Service.

If to Licensor: Union Pacific Railroad Company
Attn: Analyst – Real Estate Utilities (Folder No. 03273-13)
1400 Douglas Street, MS 1690
Omaha, Nebraska 68179

If to Licensee: PORT OF TOLEDO
496 NW Hwy 20
Toledo, Oregon 97391

Article 12. SPECIAL PROVISION – CONSTRUCTION OBSERVATION.

Licensor requires Licensee to provide monitoring of tracks and construction observation through Licensor approved observer named below during all construction and installation work. Licensee is to directly coordinate services with the named inspector:

Railpros Field Services
Email: RP.Utility@railpros.com
Phone (682)223-5271

IN WITNESS WHEREOF, the parties hereto have caused this Agreement to be executed as of the date first herein written.

UNION PACIFIC RAILROAD COMPANY

PORT OF TOLEDO

By: 
~~•Daniel Peters~~
~~Senior Manager~~

Thomas Leddy
Senior Analyst - Real Estate
Union Pacific Railroad Company

By: 
Name Printed: Lorna Davis
Title: Port Manager

NON-FLAMMABLE LIQUID PIPELINE

- CROSSING
- ENCROACHMENT
- BOTH

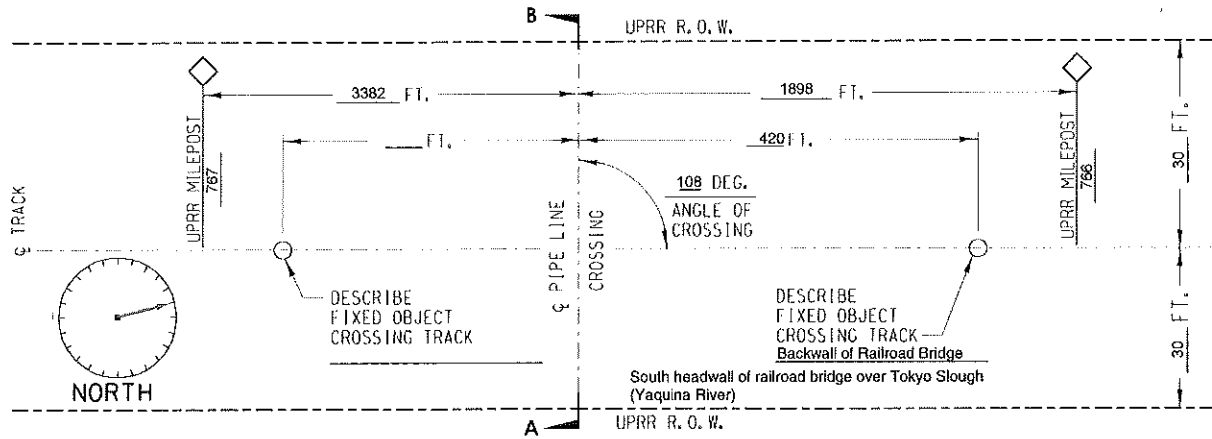

PLAN

SCALE: NONE

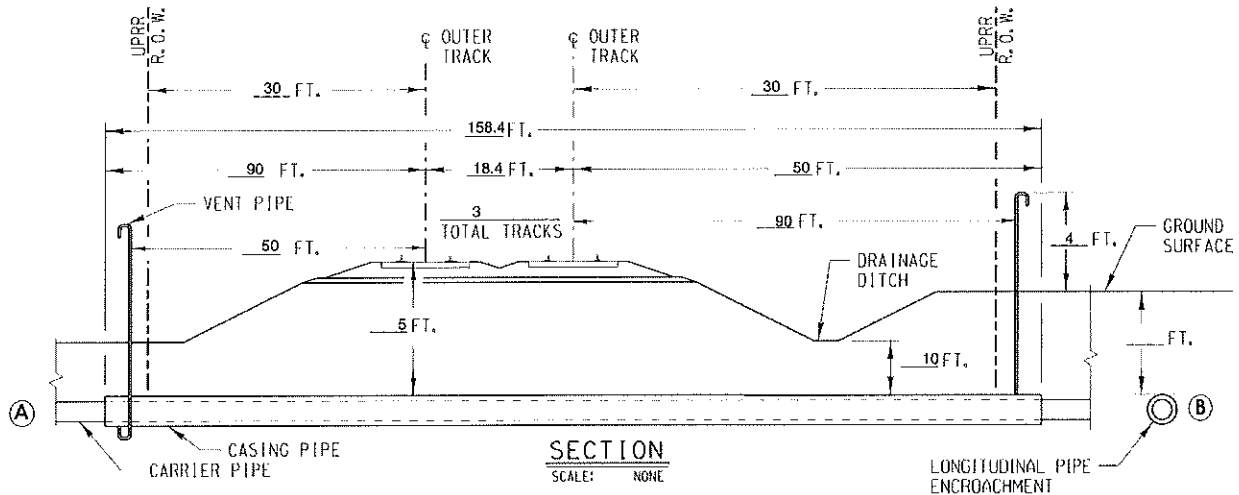

SECTION

SCALE: NONE

- NOTES:
 1) ALL DIMENSIONS MEASURED PERPENDICULAR TO THE CENTERLINE OF TRACK
 2) REFER TO AREMA VOLUME 1, CHAPTER 1, PART 5, SECTION 5.1

- A) METHOD OF INSTALLATION BORED AND JACKED
- B) DIST. FROM CENTERLINE OF TRACK TO PIPE ENCROACHMENT _____
- C) SIGNS PROVIDED? AT MINIMUM SIGNS WILL BE PROVIDED AS STATED ABOVE
- D) CARRIER MATERIAL PLASTIC, IF RCP, CLASS V? NA
 COMMODITY TO BE CONVEYED SANITARY SEWAGE
 OPERATIONAL PRESSURE 40 PSI, MAOP 70 PSI.
 WALL THICKNESS (INCH)/ SCHEDULE 40, DIAMETER 3 IN.
 CATHODIC/COATING PROTECTION NO
- E) CASING MATERIAL STEEL PIPE, IF RCP, CLASS V? NA
 TOTAL LENGTH CASING PIPE: 158.4 FT.
 WALL THICKNESS 0.35 IN, DIAMETER 10 IN.
 CATHODIC/COATING PROTECTION YES
 CASING PIPE IS SEALED AT THE ENDS.
- F) DISTANCE FROM CENTERLINE OF TRACK TO NEAR FACE OF BORING AND JACKING PITS WHEN MEASURED AT RIGHT ANGLES 40 AND 80.



BUILDING AMERICA®

EXHIBIT "A"

SUBDIVISION: Toledo Branch	
TRACK TYPE: MAINLINE	
M.P.: 766.36	LAT.: 44.621204
E.S.M.: 438+16 ±	LONG.: -123.946423
NEAREST CITY: TOLEDO	COUNTY: LINCOLN
STATE: OR	
APPLICANT: PORT OF TOLEDO	
FILE NO.: 0327313	DATE: 5/3/2021

EXHIBIT B

GENERAL TERMS AND CONDITIONS

Section 1. LIMITATION AND SUBORDINATION OF RIGHTS GRANTED.

A. The foregoing grant is subject and subordinate to the prior and continuing right and obligation of Licensor to use and maintain its entire property including the right and power of Licensor to construct, maintain, repair, renew, use, operate, change, modify or relocate railroad tracks, signal, communication, fiber optics, or other wirelines, pipelines and other facilities upon, along or across any or all parts of its property, all or any of which may be freely done at any time or times by Licensor without liability to Licensee or to any other party for compensation or damages.

B. The foregoing grant is also subject to all outstanding superior rights (including those in favor of licensees and lessees of Railroad Property) and the right of Licensor to renew and extend the same, and is made without covenant of title or for quiet enjoyment. It shall be Licensee's sole obligation to obtain such additional permission, license and grants necessary on account of any such existing rights.

Section 2. ENGINEERING REQUIREMENTS; PERMITS.

A. Licensee's Facilities will be designed, constructed, operated, maintained, repaired, renewed, modified, reconstructed, removed, or abandoned in place on Railroad Property by Licensee or its contractor to Licensor's satisfaction and in strict conformity with: (i) Licensor's current engineering standards and specifications, including those for shoring and cribbing to protect Licensor's railroad operations and facilities ("UP Specifications"), except for variances approved in advance in writing by Licensor's Assistant Vice President Engineering – Design or its authorized representative ("UP Engineering Representative"); (ii) such other additional safety standards as Licensor, in its sole discretion, elects to require, including, without limitation, American Railway Engineering and Maintenance-of-Way Association ("AREMA") standards and guidelines (collectively, "UP Additional Requirements"); and (iii) all applicable laws, rules, and regulations, including any applicable Federal Railroad Administration and Federal Energy Regulatory Commission regulations and enactments (collectively, "Laws"). If there is any conflict between UP Specifications, UP Additional Requirements, and Laws, the most restrictive will apply.

B. Licensee shall keep the soil over Licensee's Facilities thoroughly compacted, and maintain the grade over and around Licensee's Facilities even with the surface of the adjacent ground.

C. If needed, Licensee shall secure, at Licensee's sole cost and expense, any and all necessary permits required to perform any work on Licensee's Facilities.

Section 3. NOTICE OF COMMENCEMENT OF WORK; EMERGENCIES.

A. Licensee and its contractors are strictly prohibited from commencing any work associated with Licensee's Facilities without Licensor's written approval that the work will be in strict compliance with the "ENGINEERING REQUIREMENTS; PERMITS" Section of this Exhibit B. Upon Licensor's approval, Licensee shall contact both of Licensor's field representatives ("Licensor's Field Representatives") at least ten (10) days before commencement of any work on Licensee's Facilities.

B. Licensee shall not commence any work until: (1) Licensor has determined whether flagging or other special protective or safety measures ("Safety Measures") are required for performance of the work pursuant to the "FLAGGING" Section of this **Exhibit B** and provided Licensee written authorization to commence work; and (2) Licensee has complied with the "PROTECTION OF FIBER OPTIC CABLE SYSTEMS" Section of this **Exhibit B**.

C. If, at any time, an emergency arises involving Licensee's Facilities, Licensee or its contractor shall immediately contact Licensor's Response Management Communications Center at (888) 877-7267.

Section 4. FLAGGING.

A. Following Licensee's notice to Licensor's Field Representatives required under the "NOTICE OF COMMENCEMENT OF WORK; EMERGENCIES" Section of this **Exhibit B**, Licensor shall inform Licensee if Safety Measures are required for performance of the work by Licensee or its contractor on Railroad Property. If Safety Measures are required, no work of any kind may be performed by Licensee or its contractor(s) until arrangements for the Safety Measures have been made and scheduled. If no Safety Measures are required, Licensor will give Licensee written authorization to commence work.

B. If any Safety Measures are performed or provided by Licensor, including but not limited to flagging, Licensor shall bill Licensee for such expenses incurred by Licensor, unless Licensor and a federal, state, or local governmental entity have agreed that Licensor is to bill such expenses to the federal, state, or local governmental entity. Additional information regarding the submission of such expenses by Licensor and payment thereof by Licensee can be found in the "LICENSEE'S PAYMENT OF EXPENSES" Section of this **Exhibit B**. If Licensor performs any Safety Measures, Licensee agrees that Licensee is not relieved of any of responsibilities or liabilities set forth in this Agreement.

C. For flagging, the rate of pay per hour for each flagger will be the prevailing hourly rate in effect for an eight-hour day for the class of flagmen used during regularly assigned hours and overtime in accordance with Labor Agreements and Schedules in effect at the time the work is performed. In addition to the cost of such labor, a composite charge for vacation, holiday, health and welfare, supplemental sickness, Railroad Retirement and unemployment compensation, supplemental pension, Employees Liability and Property Damage, and Administration will be included, computed on actual payroll. The composite charge will be the prevailing composite charge in effect at the time the work is performed. One and one-half times the current hourly rate is paid for overtime, Saturdays and Sundays, and two and one-half times current hourly rate for holidays. Wage rates are subject to change, at any time, by law or by agreement between Licensor and its employees, and may be retroactive as a result of negotiations or a ruling of an authorized governmental agency. Additional charges on labor are also subject to change. If the wage rate or additional charges are changed, Licensee (or the governmental entity, as applicable) shall pay on the basis of the new rates and charges.

D. Reimbursement to Licensor will be required covering the full eight-hour day during which any flagger is furnished, unless the flagger can be assigned to other railroad work during a portion of such day, in which event reimbursement will not be required for the portion of the day during which the flagger is engaged in other railroad work. Reimbursement will also be required for any day not actually worked by the flaggers following the flaggers' assignment to work on the project for which Licensor is required to pay the flaggers and which could not reasonably be avoided by Licensor by assignment of such flaggers to other work, even though Licensee may not be working during such time. When it becomes necessary for Licensor to bulletin and assign an employee to a flagging position in compliance with union collective bargaining agreements, Licensee must provide Licensor a minimum of

five (5) days notice prior to the cessation of the need for a flagger. If five (5) days notice of cessation is not given, Licensee will still be required to pay flagging charges for the days the flagger was scheduled, even though flagging is no longer required for that period. An additional ten (10) days notice must then be given to Licensor if flagging services are needed again after such five day cessation notice has been given to Licensor.

Section 5. SAFETY.

A. Safety of personnel, property, rail operations and the public is of paramount importance in the prosecution of any work on Railroad Property performed by Licensee or its contractor, and takes precedence over any work on Licensee's Facilities to be performed Licensee or its contractors. Licensee shall be responsible for initiating, maintaining and supervising all safety operations and programs in connection with any work on Licensee's Facilities. Licensee and its contractor shall, at a minimum comply, with Licensor's then current safety standards located at the below web address ("Licensor's Safety Standards") to ensure uniformity with the safety standards followed by Licensor's own forces. As a part of Licensee's safety responsibilities, Licensee shall notify Licensor if it determines that any of Licensor's Safety Standards are contrary to good safety practices. Licensee and its contractor shall furnish copies of Licensor's Safety Standards to each of its employees before they enter Railroad Property.

Union Pacific Current Safety Requirements

B. Licensee shall keep the job site on Railroad Property free from safety and health hazards and ensure that their employees are competent and adequately trained in all safety and health aspects of the work.

C. Licensee represents and warrants that all parts of Licensee's Facilities within and outside of the limits of Railroad Property will not interfere whatsoever with the constant, continuous, and uninterrupted use of the tracks, property, and facilities of Licensor, and nothing shall be done or suffered to be done by Licensee at any time that would in any manner impair the safety thereof.

D. Licensor's operations and work performed by Licensor's personnel may cause delays in Licensee's or its contractor's work on Licensee's Facilities. Licensee accepts this risk and agrees that Licensor shall have no liability to Licensee or any other person or entity for any such delays. Licensee must coordinate any work on Railroad Property by Licensee or any third party with Licensor's Field Representatives in strict compliance with the "NOTICE OF COMMENCEMENT OF WORK; EMERGENCIES" Section of this **Exhibit**

E. Licensor shall have the right, if it so elects, to provide any support it deems necessary for the safety of Licensor's operations and trackage during Licensee's or its contractor's construction, maintenance, repair, renewal, modification, relocation, reconstruction, or removal of Licensee's Facilities. In the event Licensor provides such support, Licensor shall invoice Licensee, and Licensee shall pay Licensor as set forth in the "LICENSEE'S PAYMENT OF EXPENSES" Section of this **Exhibit B**.

F. Licensee may use unmanned aircraft systems ("UAS") to inspect Licensee's Facilities only upon the prior authorization from and under the direction of Licensor's Field Representatives. Licensee represents and warrants that its use of UAS on Railroad Property will comply with Licensor's then-current Unmanned Aerial Systems Policy and all applicable laws, rules and regulations, including any applicable Federal Aviation Administration regulations and enactments pertaining to UAS.

Section 6. PROTECTION OF FIBER OPTIC CABLE SYSTEMS.

Fiber optic cable systems may be buried on Railroad Property. Protection of the fiber optic cable systems is of extreme importance since any break could disrupt service to users resulting in business interruption and loss of revenue and profits. In addition to the notifications required under the "NOTICE OF COMMENCEMENT OF WORK; EMERGENCIES" Section of this **Exhibit B**, Licensee shall telephone Licensor during normal business hours (7:00 a.m. to 9:00 p.m. Central Time, Monday through Friday, except for holidays) at 1-800-336-9193 (also a 24-hour, 7-day number for emergency calls) to determine if fiber optic cable is buried anywhere on Railroad Property to be used by Licensee. If it is, Licensee shall telephone the telecommunications company(ies) involved, and arrange for a cable locator, make arrangements for relocation or other protection of the fiber optic cable, all at Licensee's expense, and will not commence any work on Railroad Property until all such protection or relocation has been completed.

Section 7. LICENSEE'S PAYMENT OF EXPENSES.

A. Licensee shall bear the entire cost and expense of the design, construction, maintenance, modification, reconstruction, repair, renewal, revision, relocation, or removal of Licensee's Facilities.

B. Licensee shall fully pay for all materials joined, affixed to and labor performed on Railroad Property in connection with the construction, maintenance, modification, reconstruction, repair, renewal, revision, relocation, or removal of Licensee's Facilities, and shall not permit or suffer any mechanic's or materialman's lien of any kind or nature to be enforced against the property for any work done or materials furnished thereon at the instance or request or on behalf of Licensee. Licensee shall promptly pay or discharge all taxes, charges, and assessments levied upon, in respect to, or on account of Licensee's Facilities, to prevent the same from becoming a charge or lien upon any property of Licensor, and so that the taxes, charges, and assessments levied upon or in respect to such property shall not be increased because of the location, construction, or maintenance of Licensee's Facilities or any improvement, appliance, or fixture connected therewith placed upon such property, or on account of Licensee's interest therein. Where such tax, charge, or assessment may not be separately made or assessed to Licensee but shall be included in the assessment of the property of Licensor, then Licensee shall pay to Licensor an equitable proportion of such taxes determined by the value of Licensee's property upon property of Licensor as compared with the entire value of such property.

C. As set forth in the "FLAGGING" Section of this **Exhibit B**, Licensor shall have the right, if it so elects, to provide any Safety Measures Licensor deems necessary for the safety of Licensor's operations and trackage during Licensee's or its contractor's construction, maintenance, modification, reconstruction, repair, renewal, revision, relocation, or removal of Licensee's Facilities, including, but not limited to supervision, inspection, and flagging services. In the event Licensor provides such Safety Measures, Licensor shall submit an itemized invoice to Licensee's notice recipient listed in the "NOTICES" Article of this Agreement. Licensee shall pay to Licensor the total amount listed on such invoice within thirty (30) days of Licensee's receipt of such invoice.

Section 8. MODIFICATIONS TO LICENSEE'S FACILITIES.

A. This grant is subject to Licensor's safe and efficient operation of its railroad, and continued use and improvement of Railroad Property (collectively, "Railroad's Use"). Accordingly, Licensee shall, at its sole cost and expense, modify, reconstruct, repair, renew, revise, relocate, or remove (individually, "Modification", or collectively, "Modifications") all or any portion of Licensee's Facilities as Licensor may designate or identify, in its sole discretion, in the furtherance of Railroad's Use.

B. Upon any Modification of all or any portion of Licensee's Facilities to another location on Railroad Property, Licensor and Licensee shall execute a Supplemental Agreement to this Pipeline Agreement to document the Modification(s) to Licensee's Facilities on Railroad Property. If the Modifications result in Licensee's Facilities moving off of Railroad Property, this Agreement will terminate upon Licensee's completion of such Modification(s) and all requirements contained within the "TERMINATION; REMOVAL OF LICENSEE'S FACILITIES" Section of this **Exhibit B**. Any such Modification(s) off of Railroad Property will not release Licensee from any liability or other obligation of Licensee arising prior to and upon completion of any such Modifications to the Licensee's Facilities.

Section 9. RESTORATION OF RAILROAD PROPERTY.

In the event Licensee, in any manner moves or disturbs any property of Licensor in connection with the construction, maintenance, modification, reconstruction, repair, renewal, revision, relocation, or removal of Licensee's Facilities, then, Licensee shall, as soon as possible and at Licensee's sole cost and expense, restore Licensor's property to the same condition as the same were before such property was moved or disturbed.

Section 10. INDEMNITY.

A. Definitions. As used in this Section:

1. "Licensor" includes Licensor, its affiliates, its and their officers, directors, agents and employees, and other railroad companies using Railroad Property at or near the location of Licensee's installation and their officers, directors, agents, and employees.
2. "Licensee" includes Licensee and its agents, contractors, subcontractors, sub-subcontractors, employees, officers, and directors, or any other person or entity acting on its behalf or under its control.
3. "Loss" includes claims, suits, taxes, loss, damages (including punitive damages, statutory damages, and exemplary damages), costs, charges, assessments, judgments, settlements, liens, demands, actions, causes of action, fines, penalties, interest, and expenses of any nature, including court costs, reasonable attorneys' fees and expenses, investigation costs, and appeal expenses.

B. Licensee shall release, defend, indemnify, and hold harmless Licensor from and against any and all Loss, even if groundless, fraudulent, or false, that directly or indirectly arises out of or is related to Licensee's construction, maintenance, modification, reconstruction, repair, renewal, revision, relocation, removal, presence, use, or operation of Licensee's Facilities, including, but not limited to, any actual or alleged:

1. Bodily harm or personal injury (including any emotional injury or disease) to, or the death of, any person(s), including, but not limited to, Licensee, Licensor, any telecommunications company, or the agents, contractors, subcontractors, sub-subcontractors, or employees of the foregoing;
2. Damage to or the disturbance, loss, movement, or destruction of Railroad Property, including loss of use and diminution in value, including, but not limited to, any telecommunications system(s) or fiber optic cable(s) on or near Railroad

Property, any property of Licensee or Licensor, or any property in the care, custody, or control of Licensee or Licensor;

3. Removal of person(s) from Railroad Property;
4. Any delays or interference with track or Railroad's Use caused by Licensee's activity(ies) on Railroad Property, including without limitation the construction, maintenance, modification, reconstruction, repair, renewal, revision, relocation, or removal of Licensee's Facilities or any part thereof, any activities, labor, materials, equipment, or machinery in conjunction therewith;
5. Right(s) or interest(s) granted pursuant to this Agreement;
6. Contents escaping from Licensee's Facilities, including without limitation any actual or alleged pollution, contamination, breach, or environmental Loss;
7. Licensee's breach of this Agreement or failure to comply with its provisions, including, but not limited to, any violation or breach by Licensee of any representations and warranties Licensee has made in this Agreement; and
8. Violation by Licensee of any law, statute, ordinance, governmental administrative order, rule, or regulation, including without limitation all applicable Federal Railroad Administration regulations.

C. THE FOREGOING OBLIGATIONS SHALL APPLY TO THE FULLEST EXTENT PERMITTED BY LAW FOR THE BENEFIT OF LICENSOR TO LOSSES CAUSED BY, ARISING FROM, RELATING TO, OR RESULTING FROM, IN WHOLE OR IN PART, THE NEGLIGENCE OF LICENSOR, AND SUCH NEGLIGENCE OF LICENSOR SHALL NOT LIMIT, DIMINISH, OR PRECLUDE LICENSEE'S OBLIGATIONS TO LICENSOR IN ANY RESPECT. NOTWITHSTANDING THE FOREGOING, SUCH OBLIGATION TO INDEMNIFY LICENSOR SHALL NOT APPLY TO THE EXTENT THE LOSS IS CAUSED BY THE SOLE, ACTIVE AND DIRECT NEGLIGENCE, GROSS NEGLIGENCE, OR WILLFUL MISCONDUCT OF LICENSOR AS DETERMINED IN A FINAL JUDGMENT BY A COURT OF COMPETENT JURISDICTION.

Section 11. TERMINATION; REMOVAL OF LICENSEE'S FACILITIES.

A. If Licensee does not use the right herein granted on Licensee's Facilities for one (1) year, or if Licensee continues in default in the performance of any provision of this Agreement for a period of thirty (30) days after written notice from Licensor to Licensee specifying such default, Licensor may, at its sole discretion, terminate this Agreement by written notice to Licensee at the address listed in the "NOTICES" Article of this Agreement. This Agreement will not terminate until Licensee complies with Paragraphs "C" and "D" of this Section found below.

B. In addition to the provisions of Paragraph "A" above, this Agreement may be terminated by written notice given by either party, without cause, upon thirty (30) days written notice to the non-terminating party at the address listed in the "NOTICES" Article of this Agreement. This Agreement will not terminate until Licensee complies with Paragraphs "C" and "D" of this Section found below.

C. Prior to the effective date of any termination described in this Section, Licensee shall submit an application to Licensor's online Utility Contracts System at [this link](#) for Licensee's removal, or if applicable, abandonment in place of Licensee's Facilities located on Railroad Property ("Removal/Abandonment

Work"). Upon the UP Engineering Representative's approval of Licensee's application for the Removal/Abandonment Work, Licensor and Licensee shall execute a separate consent document that will govern Licensee's performance of the Removal/Abandonment Work from those portions of Railroad Property not occupied by roadbed and/or trackage ("Consent Document"). Licensee shall then restore the impacted Railroad Property to the same or reasonably similar condition as it was prior to Licensee's installation of Licensee's Facilities. For purposes of this Section, Licensee's (i) performance of the Removal/Abandonment Work, and (ii) restoration work will hereinafter be collectively referred to as the "Restoration Work".

D. Following Licensee's completion of the Restoration Work, Licensee shall provide a written certification letter to Licensor at the address listed in the "NOTICES" Article of this Agreement which certifies that the Restoration Work has been completed in accordance with the Consent Document. Licensee shall report to governmental authorities, as required by law, and notify Licensor immediately if any environmental contamination is discovered during Licensee's performance of the Restoration Work. Upon discovery, the Licensee shall initiate any and all removal, remedial and restoration actions that are necessary to restore the property to its original, uncontaminated condition. Licensee shall provide written certification to Licensor at the address listed in the "NOTICES" Article of this Agreement that environmental contamination has been remediated and the property has been restored in accordance with Licensor's requirements. Upon Licensor's receipt of Licensee's restoration completion certifications, this Agreement will terminate.

E. In the event that Licensee fails to complete any of the Restoration Work, Licensor may, but is not obligated, to perform the Restoration Work. Any such work actually performed by Licensor will be at the cost and expense of Licensee. In the event that Licensor performs any of the Restoration Work, Licensee shall release Licensor from any and all Loss (defined in the "INDEMNITY" Section of this **Exhibit B**) arising out of or related to Licensor's performance of the Restoration Work.

F. Termination of this Agreement for any reason will not affect any of rights or obligations of the parties which may have accrued, or liabilities or Loss (defined in the "INDEMNITY" Section of this **Exhibit B**), accrued or otherwise, which may have arisen prior to such termination.

EXHIBIT C

INSURANCE REQUIREMENTS

In accordance with Article 5 of this Agreement, Licensee shall (1) procure and maintain at its sole cost and expense, or (2) require its Contractor(s) to procure and maintain, at their sole cost and expense, the following insurance coverage:

A. **Commercial General Liability Insurance.** Commercial general liability (CGL) with a limit of not less than \$2,000,000 each occurrence and an aggregate limit of not less than \$4,000,000. CGL insurance must be written on ISO occurrence form CG 00 01 12 04 (or a substitute form providing equivalent coverage).

The policy must also contain the following endorsement, WHICH MUST BE STATED ON THE CERTIFICATE OF INSURANCE:

- Contractual Liability Railroads ISO form CG 24 17 10 01 (or a substitute form providing equivalent coverage) showing "Union Pacific Railroad Company Property" as the Designated Job Site.

B. **Business Automobile Coverage Insurance.** Business auto coverage written on ISO form CA 00 01 10 01 (or a substitute form providing equivalent liability coverage) with a limit of not less \$2,000,000 for each accident, and coverage must include liability arising out of any auto (including owned, hired, and non-owned autos).

The policy must contain the following endorsements, WHICH MUST BE STATED ON THE CERTIFICATE OF INSURANCE:

- "Coverage For Certain Operations In Connection With Railroads" ISO form CA 20 70 10 01 (or a substitute form providing equivalent coverage) showing "Union Pacific Railroad Company Property" as the Designated Job Site.

C. **Workers' Compensation and Employers' Liability Insurance.** Coverage must include but not be limited to:

- Licensee's statutory liability under the workers' compensation laws of the state(s) affected by this Agreement.
- Employers' Liability (Part B) with limits of at least \$500,000 each accident, \$500,000 disease policy limit \$500,000 each employee.

If Licensee is self-insured, evidence of state approval and excess workers' compensation coverage must be provided. Coverage must include liability arising out of the U. S. Longshoremen's and Harbor Workers' Act, the Jones Act, and the Outer Continental Shelf Land Act, if applicable.

D. **Environmental Liability Insurance.** Environmental Legal Liability Insurance (ELL) applicable to bodily injury, property damage, including loss of use of damaged property or of property that has not been physically injured or destroyed, cleanup costs, and defense, including costs and expenses incurred in the investigation, defense, or settlement of claims, or compliance with statute, all in connection with any loss arising from the insured's performance under this Agreement. Except with respect to the limits of insurance, and any rights or duties specifically assigned to the first named insured,

this insurance must apply as if each named insured were the only named insured; and separately to the additional insured against which claim is made or suit is brought. Coverage shall be maintained in an amount of at least \$2,000,000 per loss, with an annual aggregate of at least \$4,000,000.

Licensee warrants that any retroactive date applicable to ELL insurance coverage under the policy is the same as or precedes the Effective Date of this Agreement, and that continuous coverage will be maintained for a period of five (5) years beginning from the time the work under this Agreement is completed or if coverage is cancelled for any reason the policies extended discovery period, if any, will be exercised for the maximum time allowed.

E. **Railroad Protective Liability Insurance.** Licensee must maintain for the duration of work "Railroad Protective Liability" insurance written on ISO occurrence form CG 00 35 12 04 (or a substitute form providing equivalent coverage) on behalf of Licensor only as named insured, with a limit of not less than \$2,000,000 per occurrence and an aggregate of \$6,000,000. The definition of "JOB LOCATION" and "WORK" on the declaration page of the policy shall refer to this Agreement and shall describe all WORK or OPERATIONS performed under this Agreement. Notwithstanding the foregoing, Licensee does not need Railroad Protective Liability Insurance after its initial construction work is complete and all excess materials have been removed from Licensor's property; PROVIDED, however, that Licensee shall procure such coverage for any subsequent maintenance, repair, renewal, modification, reconstruction, or removal work on Licensee's Facilities.

F. **Umbrella or Excess Insurance.** If Licensee utilizes umbrella or excess policies, and these policies must "follow form" and afford no less coverage than the primary policy.

Other Requirements

G. All policy(ies) required above (except business automobile, workers' compensation and employers' liability) must include Licensor as "Additional Insured" using ISO Additional Insured Endorsement CG 20 26 (or substitute form(s) providing equivalent coverage). The coverage provided to Licensor as additional insured shall not be limited by Licensee's liability under the indemnity provisions of this Agreement. BOTH LICENSOR AND LICENSEE EXPECT THAT LICENSOR WILL BE PROVIDED WITH THE BROADEST POSSIBLE COVERAGE AVAILABLE BY OPERATION OF LAW UNDER ISO ADDITIONAL INSURED FORM CG 20 26.

H. Punitive damages exclusion, if any, must be deleted (and the deletion indicated on the certificate of insurance), unless (a) insurance coverage may not lawfully be obtained for any punitive damages that may arise under this Agreement, or (b) all punitive damages are prohibited by all states in which this Agreement will be performed.

I. Licensee waives all rights of recovery, and its insurers also waive all rights of subrogation of damages against Licensor and its agents, officers, directors and employees for damages covered by the workers' compensation and employers' liability or commercial umbrella or excess liability obtained by Licensee required in this Agreement, where permitted by law. This waiver must be stated on the certificate of insurance.

J. All insurance policies must be written by a reputable insurance company acceptable to Licensor or with a current Best's Insurance Guide Rating of A- and Class VII or better, and authorized to do business in the state(s) in which the work is to be performed.

K. The fact that insurance is obtained by Licensee will not be deemed to release or diminish the liability of Licensee, including, without limitation, liability under the indemnity provisions of this Agreement. Damages recoverable by Licensor from Licensee or any third party will not be limited by the amount of the required insurance coverage.